



**NEW!**

# Bearing Fault Detector PLUS

USB Programmable loop powered device with 4-20mA output contained in a typical vibration sensor housing ideal for fault detection in rolling element bearings

## Highlights

- Combination 4-20 mA sensor PLUS vibration transmitter
- USB Programmable: Fine tune transmitter to your specific machine parameters
- Various output options: Integrates with your PLC system
- Output specifically tuned for sensing early faults/failures in rolling element bearings



## Typical Applications

- Motors
- Fans
- Pumps
- Critical rotating machinery
- Fixed speed rotating equipment
- Variable frequency driven machinery



**Bearing Fault Detector PLUS**  
Model 649A03

The 649A03 Bearing Fault Detector PLUS is a USB Programmable loop powered device with 4-20mA output, all contained in typical vibration sensor housing. It is specifically designed to provide early warning of typical ball/rolling element bearing faults such as cracked races, spalling, brinelling, and looseness. The model is similar to IMI's 682B05 DIN rail mounted Bearing Fault Detector; however, it is not a direct substitute. Like the 682B05, it provides a 4-20 mA output specially tuned to detect high frequency bearing faults. Unlike the 682B05, which is mounted in a box connected to an external sensor, the 649A03 has a sensor form factor that can directly mount to the machinery. It differs in that it provides several additional outputs, but can only provide one at any given time. These specialized outputs can be selected using the USB Programming function of the transmitter.

The primary use for the Bearing Fault Detector PLUS is in applications with critical rotating machinery that needs continuous monitoring. The 649A03 is specifically designed to be sensitive to high frequency faults in rolling element bearings, which indicate the early stages of damage. It serves to provide a proactive warning to any Predictive Maintenance technician by increasing its 4-20 mA output proportional to this high frequency vibration. They can use this 4-20 mA scaled output to both trend the data and create vibration alarms with a PLC or DCS to closely monitor when machinery should be shut down and its rolling element bearing should be replaced.

The Bearing Fault Detector PLUS has five different outputs which aid in fault detection, and these are user-selectable by a simple software program through a PC's USB port. The output options include RMS acceleration, True Peak acceleration, Compensated Peak acceleration, Crest Factor, and Crest factor Plus. Many of the various output options require the speed of rotation as an input for programming. Due to this feature and the nature of bearing vibration frequencies, the 649A03 is best suited for fixed speed rotating equipment; however, the Crest Factor Plus uses an algorithm which normalizes the output across various running speeds and is designed for use with variable frequency driven machinery.



Technical Specifications	
<b>Model Number</b>	<b>649A03</b>
<b>Performance</b>	
Output (Loop Power)	4-20 mA
Sampling Time	1 sec
Measurement Range (with HPF 250 Hz)	0-2 to 0-50 g pk [1][2]
Measurement Range (with HPF 2500 Hz)	0-2 to 0-50 RMS [1][2]
Measurement Range (with HPF 250 Hz)	1 to 16 [2]
Crest Factor (with HPF 250 Hz)	1 to 16 [2]
Crest Factor Plus	1 to 16 [2]
Bearing Diameter	1.57 to 39.37 in
	40 to 1000 mm
Bearing Rotation Speed	600 to 3600 RPM
	10 to 60 Hz
Linearity (Loop Powered)	10%
<b>Environmental</b>	
Temperature Range	-40 to 212 °F
	-40 to 100 °C
Storage Temperature Range	-40 to 257 °F
	-40 to 125 °C
<b>Electrical</b>	
Excitation Voltage	15 to 30 VDC
Load Resistance	50(Vs-15) Ohm
Electrical Isolation	>10 <sup>8</sup> Ohm
<b>Physical</b>	
Size (Height x Hex)	2.60 in x 1.25 in
	66 mm x 32 mm
Weight	5.7 oz
	162 gm
Mounting Thread	1/4-28 UNF
Mounting Torque	3 to 5 ft-lb
	4 to 7 Nm
Sensing Element	Piezoelectric Accelerometer
Housing Material	Stainless Steel
Sealing	Welded Hermetic
Electrical Connector	3-Pin MIL-C-5015
Electrical Connector Position	Top
Electrical Connections (Pin A)	4-20 mA Pos (+)
Electrical Connections (Pin B)	4-20 mA Neg (-)
Overload Limit (Shock)	5000 g pk
	49050 m/s <sup>2</sup> pk
<b>Supplied Accessories</b>	
081A41 Mounting stud 1/4-28 socket head set screw brass tip stainless steel 5/8" long (1)	
<b>Notes</b>	
[1] With 0.1g Step [2] Customer programmable parameters	
<b>Optional Versions</b>	
<b>M - Metric Mount</b>	
<b>All specifications are at room temperature unless otherwise specified</b>	

Model Comparison		
Feature	Bearing Fault Detector Model 682B05	Bearing Fault Detector PLUS Model 649A03
Provides Early Warning of Bearing and Gear Faults	✓	✓
Compatible with PLC, DCS, or SCADA Systems	✓	✓
High Frequency True Peak Acceleration Output	✓	✓
RMS Acceleration	✓	✓
Crest Factor	✗	✓
Crest Factor Plus	✗	✓
Compensated Peak Acceleration	✗	✓
RMS Velocity	✓	✗
Raw Vibration Signal for Diagnostics	✓	✗
Normalizes Output Using Machine Parameters	✗	✓
Utilizes Integrated Sensor	✗	✓
USB Programmable Outputs	✗	✓
Utilizes Variable External Sensor	✓	✗
Din-Rail Mounted	✓	✗

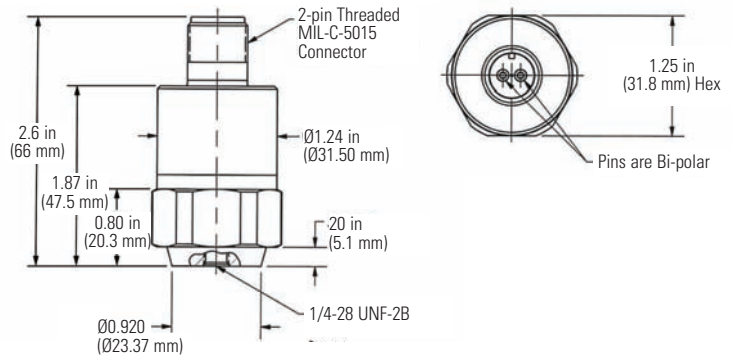

## More Bearing Monitoring Solutions from IMi Sensors!



### Bearing Fault Detector Model 682B05

- Provides early warning of bearing and gear faults
- Operates with PLC, DCS, SCADA, alarm and control systems
- Outputs 4-20 mA signals for peak acceleration and overall vibration



3425 Walden Avenue, Depew, NY 14043-2495 USA

**Toll-Free in the USA 800-959-4464**

**24-hour SensorLine<sup>SM</sup> 716-684-0003**

**Fax 716-684-3823 ■ Email imi@pcb.com**

**Website www.imi-sensors.com**

**ISO 9001 CERTIFIED ■ A2LA ACCREDITED to ISO 17025**

© 2013 PCB Group, Inc. In the interest of constant product improvement, specifications are subject to change without notice. PCB, ECHO, ICP, Modally Tuned, Spindler, Swiveler and TORKDISC are registered trademarks of PCB Group. SoundTrack LXT, Spark and Blaze are registered trademarks of PCB Piezotronics. SensorLine is a service mark of PCB Group. All other trademarks are property of their respective owners.

IMI-649A03-1013

Printed in U.S.A.



IMi Sensors designs and manufactures a full line of accelerometers, sensors, vibration switches, vibration transmitters, cables and accessories for predictive maintenance, continuous vibration monitoring, and machinery equipment protection. Products include rugged industrial ICP<sup>®</sup> accelerometers, 4-20 mA industrial vibration sensors and transmitters for 24/7 monitoring, electronic and mechanical vibration switches, the patented Bearing Fault Detector, high temperature accelerometers to +1300 °F (+704 °C), 2-wire Smart Vibration Switch, and the patented Reciprocating Machinery Protector. CE approved and intrinsically safe versions are available for most products.

Visit [www.imi-sensors.com](http://www.imi-sensors.com) to locate your nearest sales office.