



5500 PORTABLE VIBRATION METER

Installation Manual



Compact and simple to operate, these economical meters are ideal for obtaining spot measurements of machine vibration. Momentarily pressing the red pushbutton activates the meter. A vibration reading is then obtained by simply holding the probe tip against the machine and observing the reading on the LCD indicator. Comparisons to a severity chart, included in this manual, indicate the severity condition.

The 5500 provides readings in Velocity. Pressing and holding the pushbutton will “freeze” the vibration reading so that the meter can be removed from the test point without losing the reading. Releasing the pushbutton returns the meter to normal operation. The meter automatically turns off 30 seconds after the pushbutton is released.

The 5500 vibration meter is available with either English or Metric displays.

Power is supplied by a standard 9V battery. A symbol appears on the LCD indicator when the battery is low. The instrument housing is made of high impact polymer.

A Cordura® carrying case with belt loop and battery are included. Optional accessories include a 10” probe extension for difficult to reach areas.

FEATURES

- Quick vibration readings
- Velocity or Displacement
- Cordura® carrying case included
- Includes reading “hold” feature
- Auto power off extends battery life
- Is intrinsically safe for use in hazardous areas
- True RMS response

APPLICATIONS

- Motors
- Pumps
- Compressors
- Fans
- Natural Gas Engines
- Piping Vibration
- Verifying sensor and instrumentation readings

ACCESSORIES

Model 2182 Probe Extension

254mm (10”) long extension slips on vibration meter probe for measurements in tight quarters.



APPLICATION NOTE: RMS vs. PEAK Velocity Readings

The 5500 vibration meter uses a true RMS detector. As indicated in “HOW TO ORDER”, models are offered with velocity vibration readings scaled after detection for RMS or PEAK units.

The majority of the portable Velocity vibration meters that are purchased are calibrated for PEAK measurement. Most North American vibration level acceptance charts, including METRIX, and permanent vibration instruments with indicators display velocity readings in PEAK units.

If your chart and/or permanent instruments display RMS values (common in Europe) RMS calibration is recommended.

SPECIFICATIONS

Function: Portable, hand held vibration meter. Displays vibration level on LCD meter.

Measurant Mode: Velocity

Frequency Response: 10 Hz to 1000 Hz

Temperature Range: -10°C to +70°C

Hazard Rating: BASEEFA certified intrinsically safe EEx ia IIC T3; BASEEFA 03ATEX0556; (-10°C < Ta < 60°C)

Power: Alkaline 9V Dry Cell, see section 3.0b for required types

Vibration Ranges: See Table

Optional Probe Attachments: Probe Extension

OUTLINE & DIMENSIONS

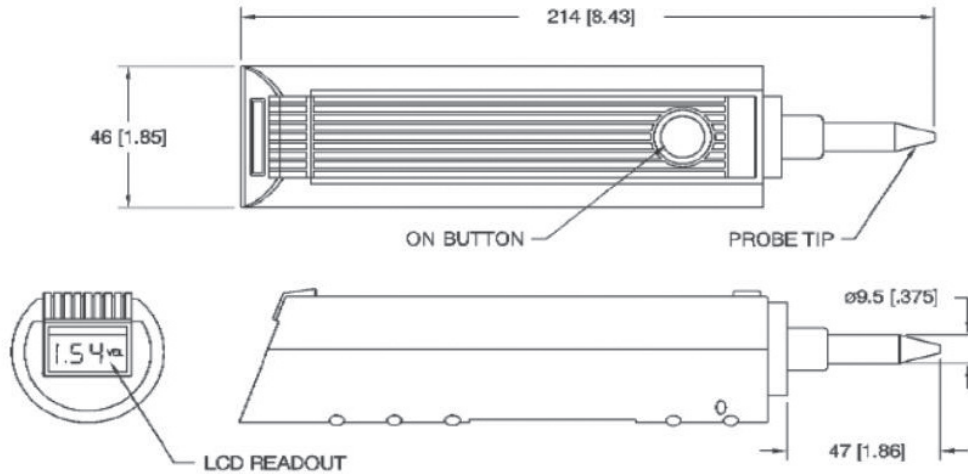

Weight:
Meter w/ Case = 1.2 Kg [2.50 lbs.]

Dimensions in mm [inches]

PRODUCT IDENTIFICATION

Model No.	Velocity*	Displacement	Certification
5500-001	2.00 inches/sec., peak	N/A	
5500-002	2.00 inches/sec., rms	N/A	
5500-003	50.00 mm/sec., peak	N/A	
5500-004	50.00 mm/sec., rms	N/A	

1.0 Operation

NOTE: The Model 5500 is certified to be intrinsically safe for use in gas group IIC. The temperature classification is T3 (200°C) with Tambient = 60°C.

1. Momentarily press the red pushbutton to activate the measuring circuit.
2. Hold the unit against the vibrating surface with just enough force to prevent chattering. Allow a few moments for the digital indicator to settle. The nameplate is marked to indicate whether the reading is in peak or rms units.
3. Pressing and holding the pushbutton will “freeze” the vibration reading, so that the unit can be removed from the test point without losing the reading. Releasing the pushbutton returns the unit to normal operation.
4. A greater than full scale reading (over-range) is indicated by the presence of two decimal points. Any reading with two decimal points should be considered to be in error.
5. The power will automatically turn off after 30 seconds unless the pushbutton is pressed again, which restarts the 30 second power on timer.

2.0 Changing the Battery

1. The unit is powered by a 9V alkaline dry cell. Depending upon the duty cycle of operation, a fresh battery should last about six months. When the battery voltage drops below 5 volts, a battery symbol will appear on the LCD display, indicating that the battery must be replaced. Vibration readings may be inaccurate when the battery symbol is displayed.
2. Loosen the two screws that retain the cover to gain access to the battery. Replace the battery with ONLY an alkaline 9V dry cell, such as:

Duracell MN1604
Panasonic 6AM6
Energizer EN22

Note: One of these battery types must be used to maintain the intrinsically safe rating.

Caution: Do not install a lithium battery.

The user will nullify the intrinsically safety certification of the Model 5500 if any battery other than an alkaline type is used. The battery must only be changed in a safe area.

The user may not replace the socket head cap screws securing the case cover of the Model 5500 with another type.

CONVERSION FORMULAS FOR VIBRATION UNITS

$$D = \left(\frac{19,100}{F} \right) V$$

$$D = \left(\frac{8,383}{F} \right)^2 A$$

$$V = \left(\frac{F}{19,100} \right) D$$

$$V = \left(\frac{3,687}{F} \right) A$$

$$A = \left(\frac{F}{8,383} \right)^2 D$$

$$A = \left(\frac{F}{3,687} \right) V$$

D = PEAK TO PEAK DISPLACEMENT - mils

V = PEAK VELOCITY - inches/sec

A = PEAK ACCELERATION - g

F = FREQUENCY - cycles/minute

1 mil = 0.001 inch

1g = ACCELERATION DUE TO GRAVITY

= 386.087 inches/second²

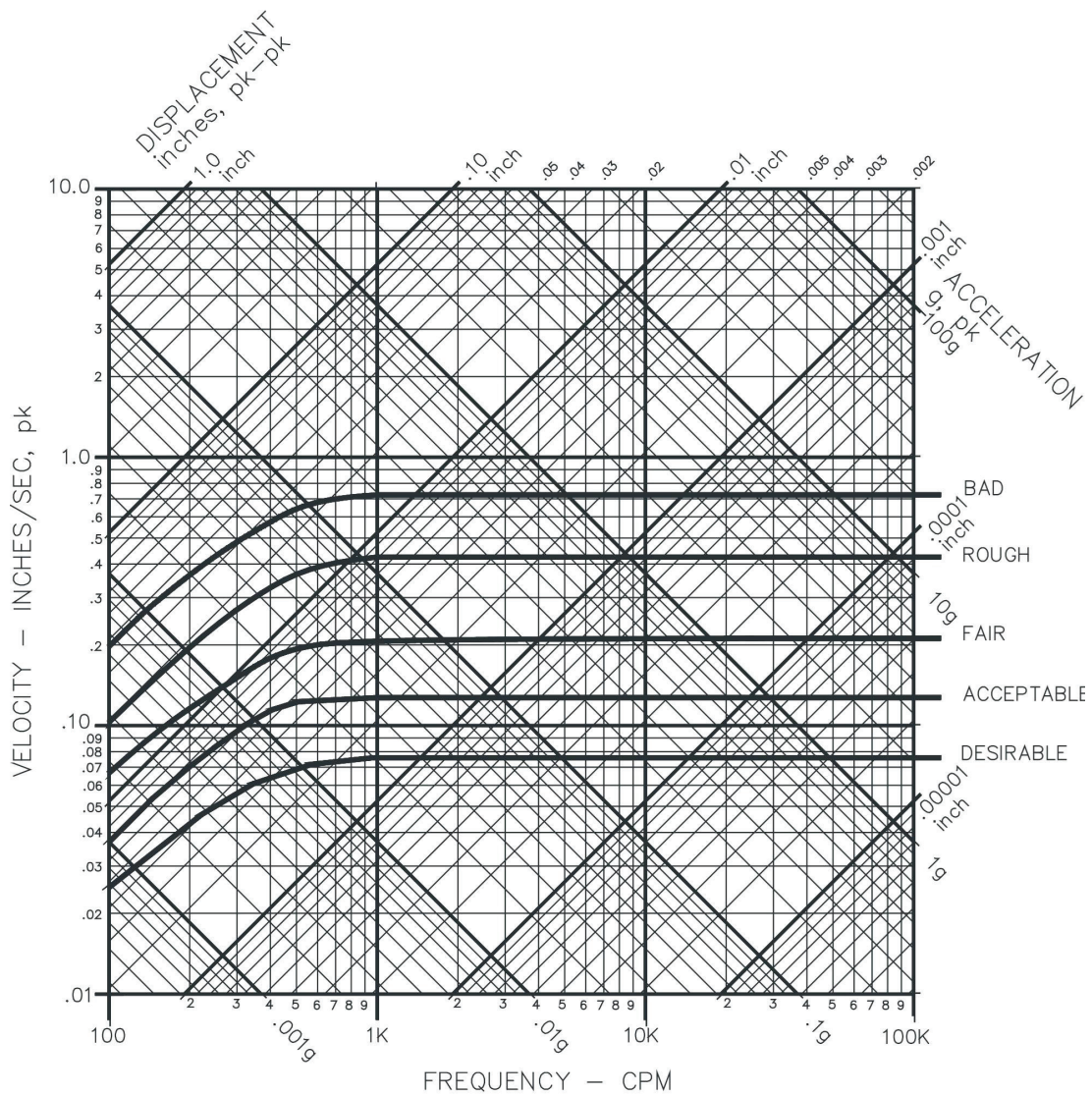

VIBRATION NOMOGRAPH AND SEVERITY CHART

.001 inch = 1 mil
 CPM = CYCLES PER MINUTE
 K = 1000

pk = PEAK VALUE
 pk-pk = PEAK TO PEAK VALUE

ENGLISH UNITS



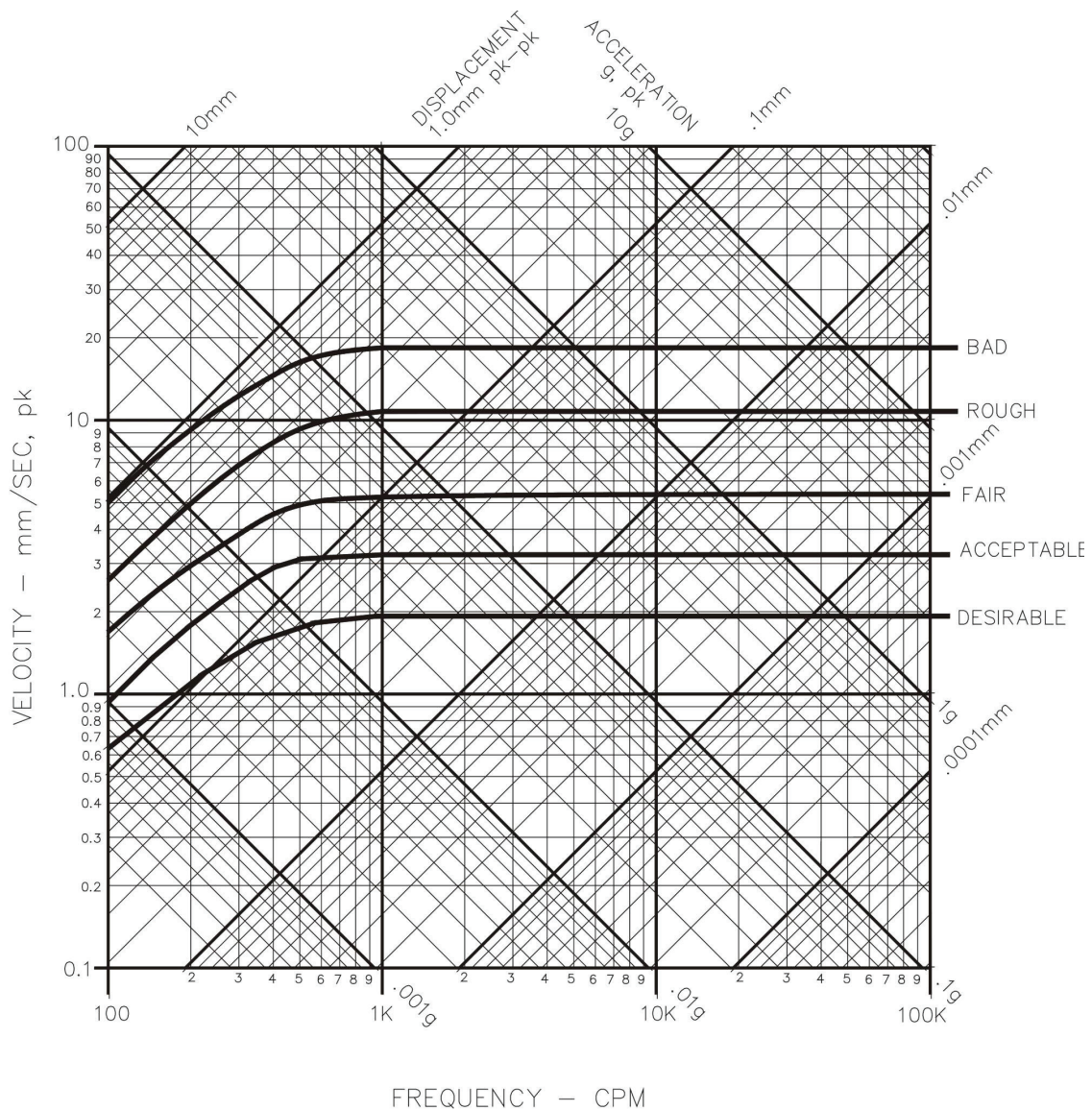

VIBRATION NOMOGRAPH AND SEVERITY CHART

mm = millimeter
 CPM = CYCLES
 PER MINUTE

pk = PEAK VALUE
 pk-pk = PEAK TO PEAK
 VALUE

METRIC UNITS

ENVIRONMENTAL INFORMATION



This electronic equipment was manufactured according to high quality standards to ensure safe and reliable operation when used as intended. Due to its nature, this equipment may contain small quantities of substances known to be hazardous to the environment or to human health if released into the environment. For this reason, Waste Electrical and Electronic Equipment (commonly known as WEEE) should never be disposed of in the public waste stream. The “Crossed-Out Waste Bin” label affixed to this product is a reminder to dispose of this product in accordance with local WEEE regulations. If you have questions about the disposal process, please contact Metrix Customer Service.



Your partner in reliability

Tel. 976 200 969 · Fax 976 362 340
www.preditec.com · info@preditec.com
Oficinas en: Madrid, Zaragoza, Barcelona,
Albacete, A Couña, Tarragona y Cádiz

info@metrixvibration.com
www.metrixvibration.com
8824 Fallbrook Dr. Houston, TX 77064, USA
Tel: 1.281.940.1802 • Fax: 1.713.559.9421
After Hours (CST) Technical Assistance: 1.713.452.9703